

Automatic Uplink Power Controller: Making Satcoms more Reliable

by Dr. Andrea Franz

We have grown accustomed to treating satellites as an extremely reliable means of communication. A significant portion of this communication is funneled through privately owned teleports throughout the world. A teleport, like Newcom International's teleport in Southern Florida, operates multiple uplinks to different satellites for services ranging from occasional and permanent TV transmissions to Internet connectivity with dedicated or shared links, for internet requirements ranging from hundreds of Mbps dedicated to a particular customer to HUBs sharing resources among thousands of VSAT stations around the world with small bandwidth requirements. Maintaining such a large operation and keeping at the same time a high link availability for each transmitted signal without having a large number of people dedicated to monitoring and adjusting transmission levels, necessarily requires the automation of this important task.

Even in a small operation, the automation of this process is a must to provide reliable services and potentiate the growth of your business. Weather is a main factor in signal quality and could easily cause severe degradation of the uplink signal to a point when the link margin is just not enough to maintain the link to the satellite. Automatic uplink power controllers, such as the UPC7000 Series from Peak Communications, help teleports to stay on the air without outages and to be able to concentrate on their main tasks of servicing their customers.

Rain Fade

The signal transmitted from a satellite earth station is subject to unwanted signal level variations caused by the natural effects of atmospheric weather conditions, commonly and generally referred to as 'rain fade,' as depicted in Figure 1. In some cases this can be severe with up to 20dB of variation seen. The goal is to maintain a constant 'link' power level. Since these fluctuations may change rapidly it is not practical to manually adjust the attenuation to keep this constant power level. Note that the rain fade is more pronounced the higher the satellite frequencies are.

Beacon Receiver

In order to achieve a constant link budget the automatic up-

link power control unit (AUPC) from Peak Communications uses the DC output from a beacon receiver. This CW beacon receiver is operating on the downlink from the same geostationary satellite as the uplink, to derive 'compensation' settings of variable attenuators that are positioned within the uplink signal path. The beacon receiver signal is affected in a similar way to the transmitted signal, apart from frequency propagation differences for which the user can make compensation adjustments.

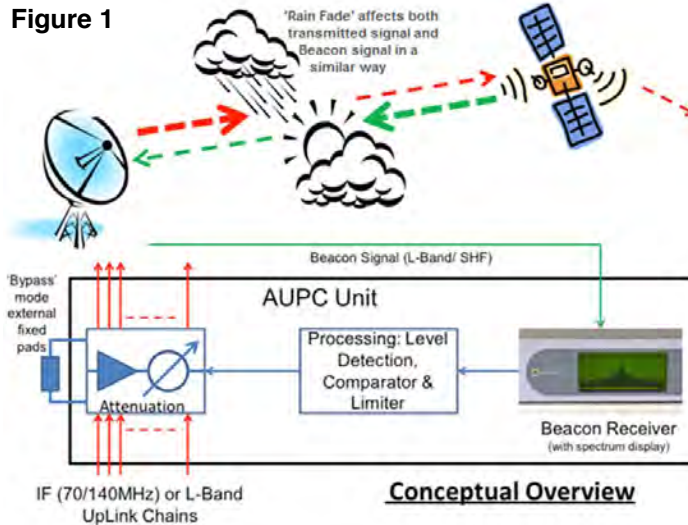

The Peak Communications Uplink Power Controller UPC7000 series feature an optional internal beacon receiver, which down converts an L-Band signal to an IF of 70 MHz. The switchable, single sweep digital anti-sideband detector prevents the unit from locking to beacon sidebands.

Calibration

The user has to calibrate the uplink power control system in 'clear-sky' conditions, which sets the maximum attenuation of the variation range in each uplink path. The attenuators used have a range of 0 to 30dB, but the maximum variation allowed can be 'limited' to avoid saturating the uplink high power amplifier (HPA) by selecting the most appropriate compensation range (2, 5, 10 or 20dB are typical values). The surplus attenuation range can also be used to set individual uplink channels to differing base levels. It is important to note that the Uplink gain/ 'link budget' and overall design should be such that a linear operation is achieved over the full adjustment range of the UPC unit.

Fail-safe Condition

For fail-safe conditions, in the event of the Beacon signal being lost or disconnected, the compensation settings will remain fixed at the point of loss and a warning flagged to the user. In the event of an internal equipment fault (includes power disconnection etc.), each compensation channel will revert to a 'bypass' mode (optional to be specified at time of order placement), where an external fixed attenuator (user selectable) is automatically placed in-circuit instead of the internal variable attenuator. Please note that if this UPC unit is being used in combination with external Peak converters (fitted with attenuators), bypass circuitry is not required and the external attenuator will remain at the previous setting.

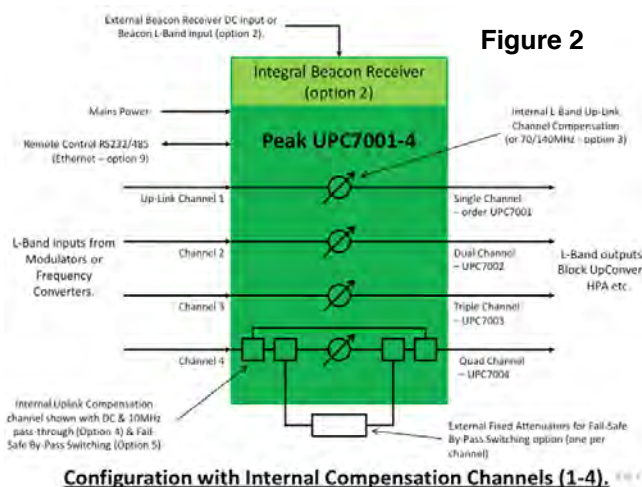

Figure 2

Configuration with Internal Compensation Channels (1-4).

Configurations

UPC7000 series controllers are housed in a 1RU high 19" rack mount chassis and are designed to provide automatic gain adjustment compensation for a number of uplink channels. The compensation and attenuator setting is based on the DC voltage from either an internal or external Beacon Receiver that is proportional to the signal level being received from a geostationary communications satellite. This can either be a dedicated Beacon signal or a looped-back carrier.

The signal levels of a number of uplink channels are adjusted via either internal attenuators (Figure 2) or the control of external attenuators fitted to Peak Communications

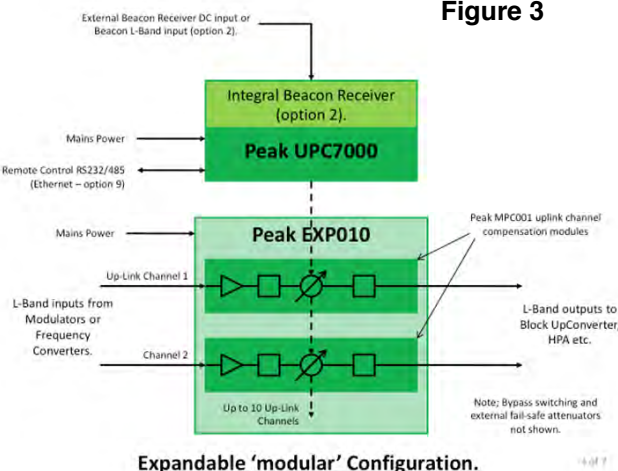

Figure 3

Expandable 'modular' Configuration.

agile or BUC frequency converters (Figure 3).

The 1RU chassis of the P7000 series supports up to 4 uplink channels. However expansion units EXP010 are provided to increase to 10-channels and beyond. These are then configured as slaves to the main UPC unit.

At the Newcom International Teleport there are multiple

uplinks to various satellite transponders. All of these uplink chains have been equipped with automatic power controls.

An example of two uplink chains is depicted in Figure 4. Both uplinks can be individually compensated for rain fade such that there won't be an outage during inclement weather, provided the calibration has been performed correctly.

Summary

Teleports are a major component of reliable satellite communications. Facilities that operate many satellite uplinks have to be able to provide their customers with timely and reliable transmissions. Rain fade during bad weather is a major potential cause for service interruptions. To avoid a signal outage it is therefore imperative that an uplink signal power

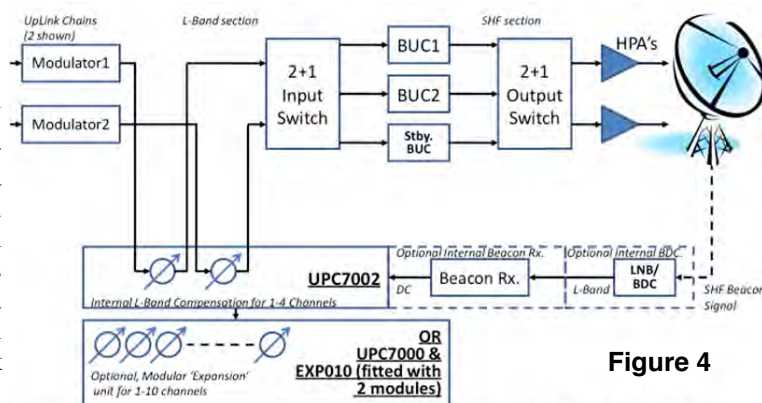

Figure 4

Example of AUPC with internal Compensation, fitted within a 2-Chain UpLink system.

compensation is implemented. With multiple uplinks this must be automated using equipment such as the P7000 from Peak Communications. After proper calibration these automatic uplink power controllers provide an effective means of assuring the highest level of reliability in satellite communications.



Dr. Andrea Franz, Partner at A.G. Franz Associates, LLC, has over 25 years of engineering and program management experience in the telecommunications, aerospace, and broadband media industries. Dr. Franz received her PhD in Electrical Engineering from the Technical University of Vienna, Austria.

She is a member of the Institute of Electrical and Electronics Engineers (IEEE) and the Society of Women Engineers (SWE). Dr. Franz is the author of several technical papers.

The author likes to thank Raul Acosta, Director of Operations at Newcom International Teleport for his expert advice and cooperation. Dr. Franz can be reached at: andrea@agfranz.com